

Relay Selection Scheme based on Maximum Likelihood Technique over Frequency Selective Fading Channel

Ahmed El-Mahdy and Ahmed M.El-Bakly

Abstract— Cooperative relay-aided transmission schemes have emerged as promising techniques for harnessing spatial diversity in wireless systems. In these schemes, the destination combines signals from the source and the intermediate relaying nodes that overhear the source, which exploits the broadcast nature of the wireless channel. In order to save power and cost and to enhance the spectral efficiency, only one relay is selected for sending the signal to the destination. The chosen relay must provide a reliable transmission. In this paper, a proposed relay selection scheme based on maximum likelihood (ML) approach over frequency selective fading channel is introduced. The proposed scheme does not require knowledge of instantaneous signal to noise ratio (ISNR) either between the source and relay or the relay and the destination. The performance of the algorithm is measured in terms of Bit Error Rate (BER) and for decode-and-forward (DF) and amplify and forward (AF) protocols. Moreover, the outage probability and the ergodic capacity are evaluated for the selected relay. Power allocation is applied in order to achieve the best power distribution between the source and the relay. The power is distributed based on minimizing the bit error rate at the output of the system.

Index Terms— Fading, maximum likelihood, relay selection scheme, power allocation.

1 INTRODUCTION

IN cooperative communication, choosing one relay from a set of relays, is a challenging task. The proper selection of the relay can effectively improve the overall performance of the network in terms of higher data rate, lower power consumption and better bit error rate performance [11]. Several algorithms were previously introduced to select one relay or more for these purposes. One of these techniques is proposed in [12] where the authors proposed opportunistic relaying where a single relay among a set of relays is selected. This selection is made depending on which relay provides the best end-to-end performance between the source and the destination. This scenario happens when all the relay nodes are maintaining a listening mode so that the relay candidates can over hear the ready to-send (RTS) packet from the source node to all neighboring nodes and the destination node sends a clear-to-send (CTS) packet to its neighboring nodes through which the relay nodes collect the instantaneous channel state information (CSI) from the source to the relay and from the relay to the destination. More specifically, the transmission of RTS from the source, allows the relays to estimate the instantaneous wireless channel $\alpha_{s,i}$ between the source s and relay i . Similarly, the transmission of CTS from the destination, allows the relays to estimate the instantaneous wireless channel $\alpha_{i,d}$ between the relay i and the destination. The channel estimates at each relay ($\alpha_{s,i}$ and $\alpha_{i,d}$), provides the quality of the total wireless path from the source to the relay and finally to the destination. The authors in [12] took into consideration these two channel estimates while choosing the best relay. The best relay i is chosen according to:

$$i = \arg \max (\min \{ |\alpha_{s,i}|^2, |\alpha_{i,d}|^2 \})$$
, where $a_{s,i}$ is the fading amplitude of the channel between the source s and relay i and $a_{i,d}$ is the fading amplitude of the channel between relay i and destination d . After the best relay i has been chosen, this relay will forward the information toward the destination. In [13], the authors proposed a relay selection algorithm where they wanted to reduce the load of the channel estimation in [12] where $2N$ channel estimations are needed to find the best relay among N relays. In addition, all the relay nodes must maintain the listening mode during the RTS and CTS packet transmission which increases the power consumption of the relay nodes. To overcome these two points, the algorithm in [13] chooses a relay node based on a predetermined threshold that guarantees a satisfying performance. This algorithm compares the entire received instantaneous signal to noise ratio (ISNR) at the relay and at the destination which are denoted by $\gamma_{s,i}$ and $\gamma_{i,d}$ with a predetermined threshold γ_t which is chosen to guarantee a satisfying performance. To understand this approach, the ISNR of each relay $\gamma_{s,i}$ is compared to γ_t ; if $\gamma_{s,i}$ is greater than or equal to γ_t , then $\gamma_{i,d}$ is compared to γ_t if $\gamma_{i,d}$ is greater than or equal to γ_t , then the chosen relay is i . If the ISNR of all the relays fail to pass the threshold, the opportunistic relaying method is used to select the relay according to this equation
$$i = \arg \max (\min \{ |\gamma_{s,i}|^2, |\gamma_{i,d}|^2 \})$$
. This technique has two main advantages compared to the opportunistic relaying. The first advantage is that the relay nodes don't always need to maintain listening mode but only the compared relay with the threshold need to be turned on. This advantage will reduce the consumed power of the relay nodes. The second advantage is that the channel estimation is only made for the compared relay node whereas the opportunistic relaying needs $2N$ channel estimations. In [14], the authors proposed partial relay selection algorithm where all the nodes are half duplex and thus cannot receive and transmit simultaneously so the transmission is performed in two orthogonal channels. This algorithm does not

Ahmed El-Mahdy is Professor in the Faculty of Information Engineering & Technology, German University in Cairo, Egypt.
Ahmed Mostafa Elbakly is Assoc. Prof., College of Engineering and Technology Arab Academy for science, Technology & Maritime transport in Cairo, Egypt.

require knowing the whole channel state information. The algorithm chooses the relay that has the best link between the source and the relay. Getting the received signal to noise ratio from the source to the relay, the best relay i is chosen according to: $i = \arg \max \{\gamma_{s,i}\}$. The authors in [15] proposed two relay selection algorithms where only one relay among relay candidates is selected according to a certain threshold. The objective of the first algorithm which is named maximum spectral efficiency scheme (MSES) is to achieve the maximum spectral efficiency and it has the same performance of the opportunistic relaying in terms of average spectral efficiency and outage probability. In this algorithm, the destination node looks for an appropriate relay node using a feedback link by probing relay candidates in a certain predetermined order. If the output SNR of the i th relay is lower than a predetermined threshold ($\gamma_i < \gamma_T$) the destination node tries to estimate the $(i+1)$ th relay path. If all the relays failed to achieve the threshold level, there will be two options: (i) pick the best relay node, (ii) buffer the data and choose not to transmit. The second proposed algorithm is named as minimum relay probing scheme (MRPS) and its objective is to minimize the number of probed relay nodes and the number of channel estimations and feedback. In [16], the authors use rate distortion theory to investigate the overhead performance tradeoff for relay selection in cooperative networks. The system considered in this paper has N relays, a single antenna and is only capable of half duplex transmission. In the first stage the information is sent from the transmitter to the relay nodes. Then in the second stage the relay with the maximum channel power gain from the relay to the destination is chosen which means that only one relay transmits the information according to this equation $j = \arg \max_{i=1,2,\dots,N} g_i$ where j is the chosen relay, and $g_i = |h_{rid}|^2$ where h_{rid} is the channel gain coefficient from the relay to the destination. In [17], four single relay selection schemes are investigated and then several multiple relay selection schemes are proposed. The first single relay selection scheme investigated is the Best Relay Selection where the relay with the highest SNR is selected. The second one is the Nearest Neighbor Selection technique in which the relay with the strongest channel from the transmitter is chosen. The third selection scheme is the Best Worst Channel Selection scheme in which the relay with the best worst channel is selected. The last scheme is the Best Harmonic Mean Selection scheme where the relay selection is done according to the harmonic mean of the two channels' magnitudes (the channel from the source to the relay node and the channel from the relay to the destination). The chosen relay in this case will be the relay that has the largest harmonic mean. After that, three multiple relay selection schemes are proposed and studied with the previous proposed single relay selection schemes. The relay selection algorithm in [18] deals with cognitive networks where secondary users opportunistically use the spectrum dedicated for the primary users. First an interference threshold I is set that guarantees the secondary users won't interfere on the primary ones, then the relays send bit which denotes the decision "yes" or "no" whether it satisfies the threshold or not. Then the related part to our work here is that the relays that satisfy the threshold send the information from the relay to the destination. The relay selection takes place in the second stage where

the relay with the best relay to the destination SNR is selected. All the previous mentioned papers proposed some relay selection techniques in order to achieve the best diversity order of the received signal at the destination. From the previous survey, we note that the considered relay selection schemes uses the ISNR and the channel is assumed to be only flat fading channel. In this thesis, we consider a relay selection scheme that uses the ML approach and does not require knowledge of the ISNR of the source-relay and the relay-destination channels. In the rest of this chapter, our proposed relay selection scheme is investigated and its performance is evaluated.

2 SYSTEM MODEL

Consider a two-hop network model that consists of only one source node, one destination node, and a relay set consisting of N candidate relays as shown in Fig. 1.

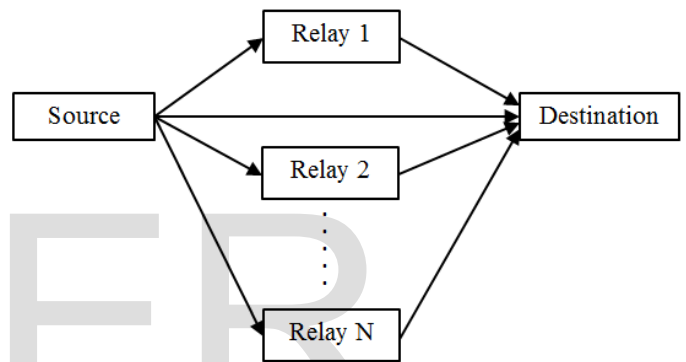

Figure 1: Multi-relay Communication System

The source, relays and destination are deployed with a single antenna. We assume that there is a direct link between the source and the destination where the information is sent directly. In the first phase, the source broadcasts the information that is received by all the relay nodes and the destination. In the second phase, only the selected relay will either decode and forward the information to the destination or amplifies and forward the information to the destination according to the relay type. The communication is divided into two phases and the channels introduce ISI at the received signal. Thus, after the first phase, the received signals at the relay nodes and at the destination are given respectively by:

$$r_{s,j}(k) = \sum_{l=0}^{L-1} \hat{h}_{s,j} s_p(k-l) + n_{s,j}(k) \tag{1}$$

$$r_{s,d}(k) = \sum_{l=0}^{L-1} \hat{h}_{s,d} s_p(k-l) + n_{s,d}(k) \tag{2}$$

where L is the number of delay paths and k is the symbol number.

Fig. 2 shows the effect of the frequency selective channels on the received signal. In the second phase, the relay sends the data to the destination according to the relay processing protocol used.

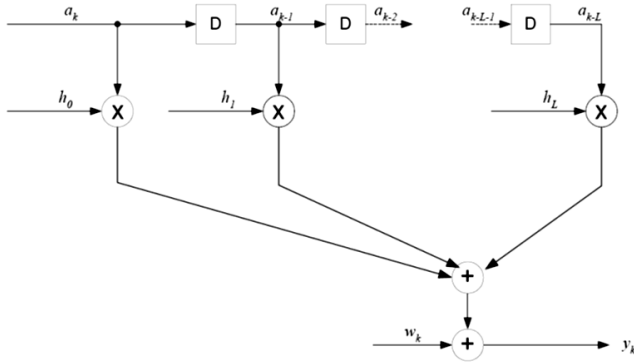

Figure 2: Multipath channel effect

3 PROPOSED RELAY SELECTION ALGORITHM

3.1 Mathematical Formulation

The first step in the proposed algorithm is sending a ready-to-send (RTS) message by the source which is received by the N relays and the destination. This message contains only pilot sequence and doesn't contain any information. The pilot signal $S_p(t)$ is transmitted with the same carrier frequency and the same power used for the payload data transmission later on. This pilot sequence is used to estimate the channel between the source and the relays $h_{s,i}$ ($j = 1, 2, \dots, N$) and the channel between the source and the destination $h_{s,d}$. On the other hand, the destination sends a clear-to-send (CTS) message to the source and to all the relays. This message is used to estimate the channel between the relays and the destination $h_{i,d}$ ($j = 1, 2, \dots, N$). The proposed relay selection scheme is based on the maximum likelihood function of the received signal at the relays. To get the likelihood function; we evaluate the probability density function of the observation over frequency selective fading channel. Using (1) and under assumption of Gaussian noise, the likelihood function of $r_{s,j}(k)$ can be written as:

$$f_k(r_{s,j}(k)) = \frac{1}{\sqrt{2\pi\sigma_n^2}} \exp\left\{-\frac{1}{\sigma_n^2} \left| r_{s,j}(k) - \sum_{l=0}^{L-1} \hat{h}_{s,j} s_p(k-l) \right|^2\right\}; \quad j = 1, 2, \dots, N \quad (3)$$

where $S_p(k)$ is the pilot symbols. The best relay from the source side is chosen as the relay which maximizes the conditional likelihood function given by (5) with respect to j . This maximization is equivalent to minimization of the following maximum likelihood (ML) metric with respect to j :

$$X_{s,j}(k) = \left| r_{s,j}(k) - \sum_{l=0}^{L-1} \hat{h}_{s,j} s_p(k-l) \right|^2; \quad j = 1, 2, \dots, N \quad (4)$$

$$X_{j,d}(k) = \left| r_{j,d}(k) - \sum_{l=0}^{L-1} \hat{h}_{j,d} s_p(k-l) \right|^2; \quad j = 1, 2, \dots, N \quad (5)$$

3.2 Description of the proposed algorithm

The proposed relay selection algorithm is described as follows. First, in the source side, the relay which has the minimum ML metric given by (4) is determined. Secondly, in the destination side, the relay which has the minimum ML metric given by (5) is determined. Then we compare the ML metrics of the other sides of the determined relays. The relay which has the minimum one is the selected relay. The proposed algorithm can be summarized as follows:

- 1) Set $j = 1$, and let $X_{s,min}(t) = X_{s,j}(t)$ and $X_{min,d}(t) = X_{j,d}(t)$
- 2) if $j = n$ then go to step 6 else $j = j + 1$
- 3) If $X_{s,j}(t) < X_{s,min}(t)$ then $X_{s,min}(t) = X_{s,j}(t)$ and $z = j$
- 4) If $X_{j,d}(t) < X_{min,d}(t)$ then $X_{min,d}(t) = X_{j,d}(t)$ and $y = j$
- 5) go to step 2
- 6) if $X_{z,d}(t) < X_{s,y}(t)$ then the chosen relay is z else the chosen relay is y

Then, after selecting the relay the source transmits the information data to the selected relay. If the decode and forward protocol is used, the selected relay decodes the entire received data, corrects it, and re-encodes it and then sends it to the destination. If the amplify and forward protocol is used, the selected relay amplifies the received signal and forward it to the destination. The received signal at the destination from the selected relay is used to extract the transmitted symbols.

3.3 Zero Forcing Equalizer

Frequency selective fading channels introduce interference at the destination due to multipath. The resulting interference, inter-symbol interference (ISI), degrades the performance of the communication system. Two signals suffering from ISI are received at the destination; one received from the selected relay and the other signal is received directly from the source through the direct link. The two signals are combined as shown in Fig. 3. For multipath channel, the two received sequences at the destination in discrete form at symbol n ($n = 0, 1, \dots, N_s - 1$) are given by:

$$r_{s,d}[n] = \sum_{k=0}^{L-1} \hat{h}_{s,d}^* [k] s[n-k] + w_{s,d}[n] \quad (6)$$

$$r_{z,d}[n] = \sum_{k=0}^{L-1} \hat{h}_{z,d}^* [k] s[n-k] + w_{z,d}[n] \quad (7)$$

Where L is the number of paths, and $w_{s,d}[n]$ and $w_{z,d}[n]$ are the additive white Gaussian noise with variance σ_w^2 . Equalizer is required to minimize the effect of ISI and to eliminate the ef-

fect of the channel.

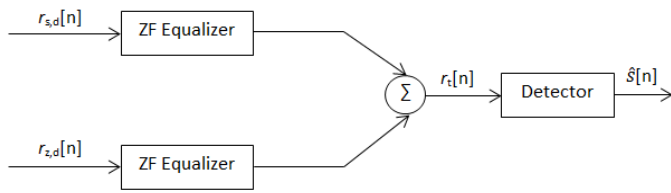

Figure 3: Combining the received signals with frequency selective fading channels.

One of the equalizers is the Zero Forcing Equalizer. This method is called zero-forcing equalization since the ISI component at the equalizer output is forced to zero. Zero forcing equalizer refers to a form of linear equalization algorithm used in communication systems which applies the inverse of the frequency response of the channel. The zero-forcing equalizer applies the inverse of the channel frequency response to the received signal, to restore the signal after the channel. For a channel with frequency response $F(f)$ the zero forcing equalizer $C(f)$ is constructed by $C(f) = 1/F(f)$. Thus the combination of channel and equalizer gives a flat frequency response and linear phase $F(f)C(f) = 1$. It is noted that the zero-forcing equalizer removes all ISI, and is ideal when the channel is noiseless.

3.4 Power Allocation

In order to achieve power distribution between the source and the selected relay, power allocation at the source and the relay nodes can be performed. There are many power allocation protocols presented in cooperative communication field. Based on [21], we can achieve optimum power allocation with the help of an optimization parameter K_s . This optimization parameter for power allocation denotes the fraction of power used by the source when transmitting the data. The rest of the available power will be used by the selected relay in order to transmit the data to the destination. In order to perform power allocation, the optimization parameter K_s is introduced to change the power transmitted by the source and the relays. It is noted that $0 \leq K_s \leq 1$. In the first time slot, the source transmits the required data to both the set of relays and the destination. The received signals by the relay j and the destination d from the source s are given respectively by:

$$r_{s,j}(k) = \sqrt{K_s} \sum_{l=0}^{L-1} \hat{h}_{s,j} s(k-l) + n_{s,j}(k) \quad (8)$$

$$r_{s,d}(k) = \sqrt{K_s} \sum_{l=0}^{L-1} \hat{h}_{s,d} s(k-l) + n_{s,d}(k) \quad (9)$$

where P is the available power shared by the source and the selected relay, $r_{s,j}(k)$ is the received signal from the source at the relay and $r_{s,d}(k)$ is the received signal from the source at the destination. In the second time slot, the relay selection takes place according to the proposed selection technique and then either it decodes and forward the signal or it directly amplifies it and forwards it to the destination. In both cases, the power

used in transmission by the selected relay will be the rest of the available power P . From (3.20) and (3.21), it is clear that the source have used a fraction of K_s from the total available transmitting power P . So the rest of the available power is $(1-K_s)P$. After the second time slot, the received signal at the destination d from the selected relay z assuming the relay uses DF protocol, can be written as:

$$r_{z,d}(k) = \sqrt{(1-K_s)P} \sum_{l=0}^{L-1} \hat{h}_{z,d} s_e(k-l) + n_{z,d}(k) \quad (10)$$

Moreover, in case of AF protocol, $r_{z,d}(k)$ can be written as:

$$r_{z,d}(k) = \sqrt{(1-K_s)P} \sum_{l=0}^{L-1} \hat{h}_{z,d} G_z r_{s,z}(k-l) + n_{z,d}(k) \quad (11)$$

where G_z is the gain of the selected relay z . Let $r_{s,z}(k)$ denotes the received signal at the selected relay z from the source s in the first time slot. To achieve the optimum power allocation, we have to get an optimum value for K_s as it is the main parameter that controls the fraction of power taken by the source and the selected relay. Finally, the optimization problem can be formulated as:

$$\min_{s.t. 0 \leq K_s \leq 1} P_e(K_s) \quad (12)$$

where P_e is the bit error rate (BER) of the proposed scheme. Now its obvious that the division of the total available transmitting power P between the source and the selected relay is performed based on minimizing the errors in the received signal by the destination; i.e. determine the optimum value for the optimization factor K_s which minimizes the BER.

3.5 Outage Probability

Another way to measure the proposed scheme performance is the outage probability. The outage probability can be defined as the probability of dropping the signal. The signal is dropped if the total ISNR at the destination falls below certain threshold [22]. The outage probability can be written as:

$$P_{out}(\gamma) = P_r(\gamma_{sum} < \gamma_{th}) \quad (13)$$

Where $P_{out}(\gamma)$ is the outage probability in terms of the instantaneous SNR γ , $P_r(\cdot)$ denotes the portability of a given action to happen, γ_{th} is a threshold value for the ISNR, and finally γ_{sum} is the sum of the instantaneous signal to noise ratio values of the links used to the path to the destination.

In our system, there are three links with three different ISNR; the direct link from the source to the destination, the link from the source to the selected relay and the link from the selected relay to the destination. It has to be noted that if the selected relay uses the DF protocol, the link from the source to the selected relay will not affect the outage probability since the relay removes the channel effect and re-encodes the transmitted data. Then, γ_{sum} in this case is given by:

$$\gamma_{sum} = \gamma_{z,d} + \gamma_{s,d} \quad (14)$$

Where $\gamma_{z,d}$ is the ISNR of the received signal at the destination from the selected relay z . If the selected relay uses the AF protocol, the outage probability is affected by the three links: source-destination link, source-relay link, and relay-destination link. Then, γ_{sum} in this case is given by [22]:

$$\gamma_{sum} = \frac{\gamma_{s,z} \gamma_{z,d}}{\gamma_{s,z} + \gamma_{z,d} + 1} + \gamma_{s,d} \quad (15)$$

4 SIMULATION AND RESULTS

In this section, the numerical results of the simulations are presented in order to evaluate the performance of the proposed relay selection algorithm. All the results are obtained using MATLAB software for perfectly known frequency selective fading channels. The proposed scheme is investigated under both the decode-and-forward and the amplify-and-forward relaying protocol. The simulation parameters are as follows: The number of data bits is $N = 100000$, the type of modulation is binary phase shift key (BPSK) and the number of relays is four. It is assumed that the power used by the source and the relay to transmit the data is unity. The path loss factor is taken into account in the simulations done.

4.1 Bit Error Rate Performance

The BER performance of the proposed relay selection algorithm is investigated. The results are shown in Figures 4 and 5 for DF and AF protocols respectively. The figures show that the performance of the proposed algorithm is better than the threshold based. For the DF protocol, the proposed algorithm outperforms the threshold-based relay selection algorithm by about 3.5 dB at $BER = 10^{-3}$; While it outperforms the direct link by about 5 dB at the same BER. The MRC has better performance than the proposed algorithm by about 3 dB at $BER = 10^{-3}$. For AF protocol, the proposed algorithm outperforms the threshold-based relay selection algorithm and the direct link by about 2 dB at $BER = 10^{-3}$. The MRC has better performance than the proposed algorithm by about 4:5 dB at the same BER. Finally, by comparing Figures 4 and 5, we have seen that the performance of the proposed relay selection algorithm using DF protocol is better than the performance of the proposed relay selection algorithm using AF protocol. At $BER = 10^{-3}$, the difference in performance is about 3dB.

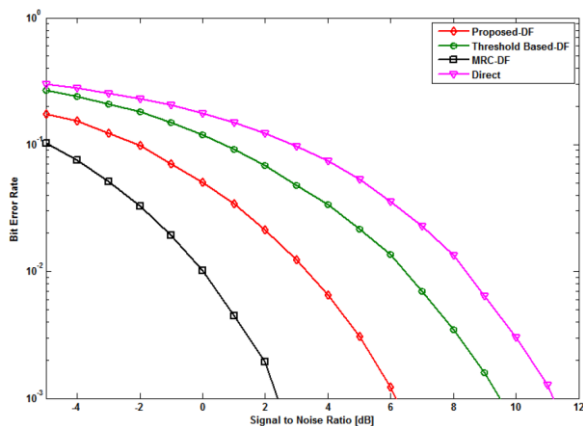

Figure 4: Performance comparison of various types of relay selection algorithms using DF protocol with frequency selective channels.

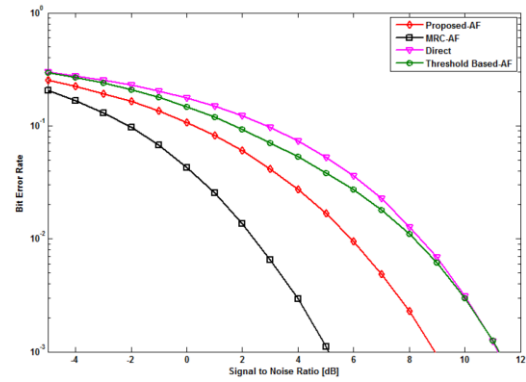

Figure 5: Performance comparison of various types of relay selection algorithms using AF protocol with frequency selective channels.

4.2 Power Allocation

The total power available in the system can be shared by the source and the selected relay node based on optimization of the parameter K_s . Simulations are performed in order to find an optimum value of K_s which gives the minimum BER. Tables 1 and 2 show the results of the optimization process for both DF and AF relay protocols. It is clear from the tables that the values of the optimization parameter K_s converges to an optimum value where the BER is minimum at this value. This optimum value in case of DF protocol is $K_s = 0.31$ and in AF protocol is $K_s = 0.47$.

Table 1: Power allocation parameters for DF relay protocol with frequency selective fading channels.

SNR [dB]	K_s	BER
-20	0.57	0.3524
-15	0.52	0.2390
-10	0.46	0.1031
-5	0.44	0.0123
0	0.31	10^{-3}
5	0.31	10^{-5}

Table 2: Power allocation parameters for AF relay protocol with frequency selective fading channels.

SNR [dB]	K_s	BER
-20	0.99	0.3783
-15	0.90	0.2871
-10	0.84	0.1475
-5	0.79	0.0261
0	0.68	0.0003
5	0.68	10^{-5}

4.3 Achievable Rate

One of the important parameters on which the performance of the system is based on is the achievable rate by this system. The achievable rate is the maximum capacity that the system can achieve. The capacity means that how many bits can be sent in one second [23]. In order to get the achievable rate, we assume that the destination terminal has perfect knowledge of the channels from the source to the destination $h_{s,d}$ and from the relay to the destination $h_{r,d}$. Also the relay has perfect knowledge of the channel from the source to the relay $h_{s,r}$. Achievable rate is investigated using the assumption that $E_{s,d}/N_o = E_{z,d}/N_o = 10$ dB where $E_{s,d}$ is the energy of the transmitted signal from the source to the destination, $E_{z,d}$ is the energy of the transmitted signal from the selected relay z to the destination, and N_o is the noise spectral density. Also it is assumed that the channel gains $h_{s,z}$, $h_{z,d}$, and $h_{s,d}$ have a power of unity. Fig. 6 show the ergodic capacities of the DF relay protocol and AF relay protocol for the proposed relay selection technique.

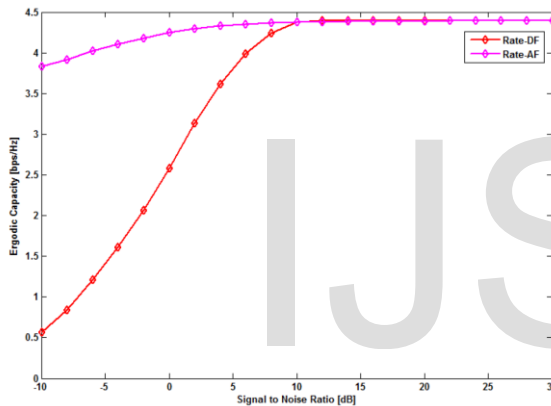

Figure 6: Comparison of the ergodic capacities for both DF and AF protocols with frequency selective channels.

We can conclude from the results that the capacity in case of DF protocol is limited when the SNR is poor unlike the case of AF protocol which has a better ergodic capacity in low SNR values. As the SNR increases, the two curves will increase till they reach the same ergodic capacities. When using the DF protocol, the ergodic capacity will increase rapidly with the increase of the signal-to-noise ratio.

4.4 Outage Probability of the proposed algorithm

The outage probability described above is simulated and the results are shown in Fig. 7 which shows the outage probability for DF protocol with three threshold values: SNR=5, 10, and 15. The values of these thresholds are chosen such as one is small, one is medium and one is large. These values are selected to show the dependence of the outage probability on the selected threshold. The results show that for low SNR, the outage probability is large and then decreases as the SNR increases. The figure also shows that as the threshold increases, the outage probability becomes worse. This is because the

probability of the instantaneous SNR to be lower than the threshold increases.

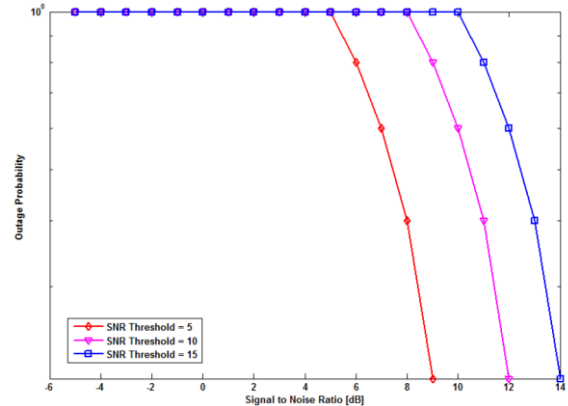

Figure 7: Outage Probability for DF protocol with frequency selective fading channels.

5 CONCLUSIONS

A relay selection scheme based on the maximum likelihood technique was introduced in a dual-hop multi-relay cooperative communication system. The proposed relay selection technique has shown a better BER performance than using the direct link only and the threshold based technique. This is because the proposed relay selection scheme is based on the optimum ML approach. The results showed that decode and forward processing protocol performance is better than that of amplify and forward processing protocol. That is because amplify and forward protocol amplifies the noise along with the received signal. However, amplify and forward protocol has better ergodic capacity than decode and forward protocol. The results also showed that when using channel estimation, there was error and so the estimated channel does not converge with the perfect channel but as the SNR increases, the two channels finally converge. Therefore the performance gets better and the MSE between the estimated and true channel also converges. The outage probability differs with the threshold value given for the ISNR.

REFERENCES

- [1] P. Jayasinghe, "Performance analysis of mimo dual-hop af relay networks over asymmetric fading channels," Master's thesis, University of Oulu, Department of Communications Engineering, May, 2014.
- [2] W. Panichpattanakul, Cooperative Communications in Ad Hoc Networks. PhD thesis, National Polytechnic Institute of Toulouse (INP Toulouse), November, 2010.
- [3] T.-Y. Wang and J.-Y. Wu, "Cooperative communications using reliability forwarding relays," IEEE TRANSACTIONS ON COMMUNICATIONS, vol. 61, no. 5, pp. 1776-1785, May 2013.
- [4] X. Liang, S. Jin, X. Gao, and K.-K. Wong, "Outage performance for decode-and-forward two-way relay network with multiple interferers and noisy relay," IEEE TRANSACTIONS ON COMMUNICATIONS, vol. 61, no. 2, pp. 521-531, February 2013.
- [5] Q. F. Zhou, Y. Li, F. C. M. Lau, and B. Vucetic, "Decode-and-forward two-way relaying with network coding and opportunistic relay selection," IEEE TRANSACTIONS ON COMMUNICATIONS, vol. 58, no. 11, pp. 3070-3076, November 2010.

- [6] P. Liu, S. Gazor, M. Kim, and D. I. Kim, "Noncoherent amplify-and-forward cooperative networks: Robust detection and performance analysis," *IEEE TRANSACTIONS ON COMMUNICATIONS*, vol. 61, no. 9, pp. 3644–3659, September 2013.
- [7] K.-S. Hwang, M. Ju, and M.-S. Alouini, "Outage performance of opportunistic two-way amplify-and-forward relaying with outdated channel state information," *IEEE TRANSACTIONS ON COMMUNICATIONS*, vol. 61, no. 9, pp. 3635–3643, September 2013.
- [8] C.-L. Wang, T.-N. Cho, and K.-J. Yang, "On power allocation and relay selection for a two-way amplify-and-forward relaying system," *IEEE TRANSACTIONS ON COMMUNICATIONS*, vol. 61, no. 9, pp. 3146–3155, August 2013.
- [9] L. Yang, K. Qaraqe, E. Serpedin, and M.-S. Alouini, "Performance analysis of amplify-and-forward two-way relaying with co-channel interference and channel estimation error," *IEEE TRANSACTIONS ON COMMUNICATIONS*, vol. 61, no. 6, pp. 2221–2231, June 2013.
- [10] S. Bharadwaj and N. B. Mehta, "Accurate performance analysis of single and opportunistic af relay cooperation with imperfect cascaded channel estimates," *IEEE TRANSACTIONS ON COMMUNICATIONS*, vol. 61, no. 5, pp. 1764–1775, May 2013.
- [11] V. K. Shah and A. P. Gharage, "A review on relay selection techniques in cooperative communication," *International Journal of Engineering and Innovative Technology (IJEIT)*, vol. 2 issue 5, pp. 65–69, November 2012.
- [12] A. Bletsas, A. Khisti, D. P. Reed, and A. Lippman, "A simple cooperative diversity method based on network path selection," *IEEE JOURNAL ON SELECTED AREAS IN COMMUNICATIONS*, vol. 24 no. 3, pp. 659–672, March 2006.
- [13] K.-S. Hwang and Y. chai Ko, "An efficient relay selection algorithm for cooperative networks," *Vehicular Technology Conference*, pp. 81–85, 2007.
- [14] K. I., T. J., M. S., and G. N., "Amplify-and-forward with partial relay selection," *IEEE Communications Letters*, vol. 12 no.4, pp. 235–237, April 2008.
- [15] K.-S. Hwang, Y.-C. Ko, and M.-S. Alouini, "Low complexity cooperative communication with switched relay selection and adaptive modulation," *IEEE 69th Vehicular Technology Conference*, pp. 1–5, April 2009.
- [16] H. Feng and J. Leonard J. Cimini, "Overhead-performance tradeoff for relay selection in cooperative networks," *46th Annual Conference on Information in Sciences and Systems (CISS)*, pp. 1–6, March 2012.
- [17] Y. Jing, Jafarkhani, and Hamid, "Single and multiple relay selection schemes and their achievable diversity orders," *IEEE Transactions on Wireless Communications*, vol. 8 no.3, pp. 1414–1423, March 2009.
- [18] H. S.I., A. M., Q. K., and H. M., "Reactive relay selection in underlay cognitive networks with fixed gain relays," *IEEE International Conference on Communications (ICC2012)*, pp. 1784–1788, June 2012.
- [19] K. T. Hemachandra and N. C. Beaulieu, "Outage analysis of opportunistic scheduling in dual-hop multiuser relay networks in the presence of interference," *IEEE TRANSACTIONS ON COMMUNICATIONS*, vol. 61, no. 5, pp. 1786–1796, May 2013.
- [20] S. Atapattu, Y. Jing, H. Jiang, and C. Tellambura, "Relay selection schemes and performance analysis approximations for two-way networks," *IEEE TRANSACTIONS ON COMMUNICATIONS*, vol. 61, no. 3, pp. 987–998, March 2013.
- [21] M. M. Fareed and M. Uysal, "A novel relay selection method for decode and forward relaying," *Canadian Conference of Electrical and Computer Engineering*, 2008. CCECE 2008., pp. 135–140, May 2008.
- [22] C. Alexandre and R. Fernandes, "Outage performance of cooperative amplify-and-forward ofdm systems with nonlinear power amplifiers," *IEEE 13th International Workshop on Signal Processing Advances in Wireless Communications (SPAWC)*, pp. 459–463, June 2012.
- [23] R. U. Nabar, H. Bolcskei, and F. W. Kneubuhler, "Fading relay channels: Performance limits and space time signal design," *JOURNAL ON SELECTED AREAS IN COMMUNICATIONS*, vol. 22 no. 6, pp. 1099–1109, August 2004.